

**Cup Filling and Closing Machines for the
Yellow Fat Industry**

ЦАМБА

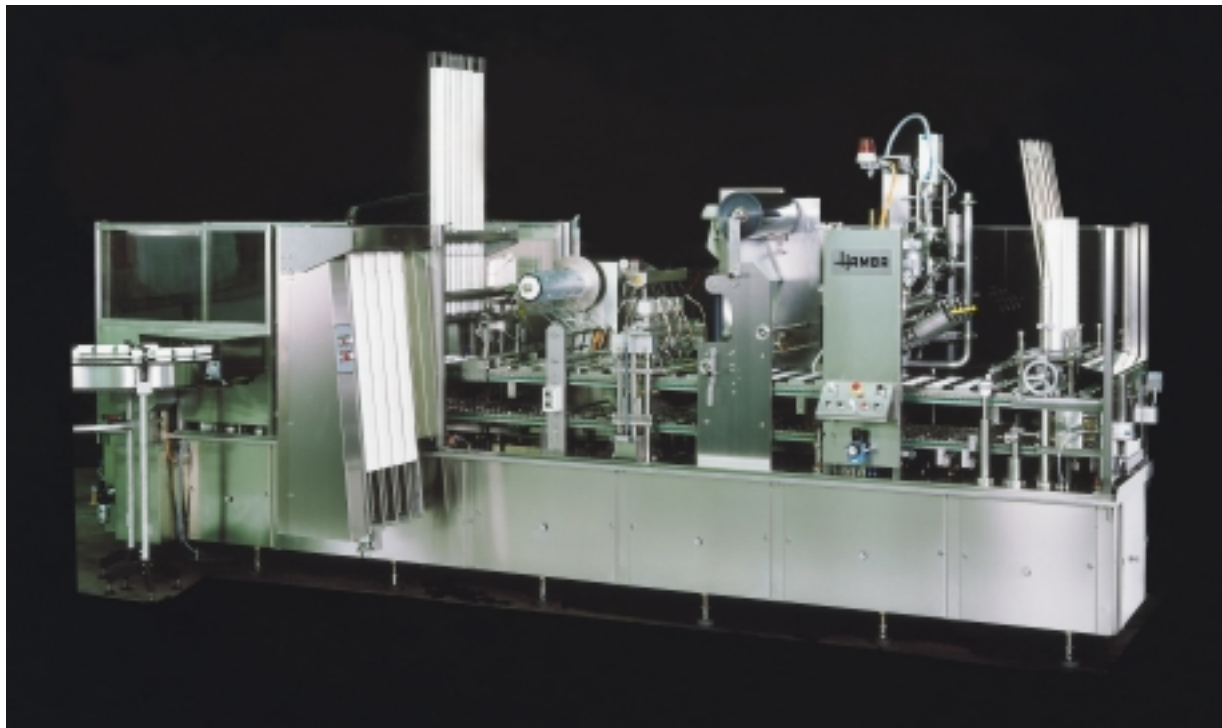

HAMBA Cup Filler designed for the Filling of Spreadable Fats



The solution of your filling and packing problem – customized!

Margarine and fat product in any qualities and packaging materials, e.g. full fat, low fat or fat reduced margarine products and cooking fats – HAMBA has the fitting solution universally, economically and orientated to your future

needs. The delivery range of HAMBA filling and closing machines designed for margarine, edible fats, spreadable low fat products and butter covers a filling performance of 800 kg / hour to 12.600 kg / hour corresponding to the actually available process facilities.

Flexible and high performance – our delivery range:

HAMBA Rotary Fillers for Margarine:

- HAMBA Cup Fillers series 5000 – Capacity up to 3.600 kg / hour (continuously adjustable)
- HAMBA Cup Fillers series 5110 – Capacity up to 5.400 kg / hour (continuously adjustable)
- Filling quantity ranges: 20 gr – 2.500 gr

HAMBA Filling and Closing Lines for Margarine – multi lane design:

- Capacity up to 12.600 kg (continuously adjustable)
- complete margarine lines – starting from cup feeding device up to final packaging
- Cup Filling and Closing Machines Series 6000 and 8000 – available in 2-, 3-, 4-, 6- and 8-lane design
- Filling range: 50 – 2.000 gr

**The differential – piston – filler
the heart of our margarine fillers designed for butter,
margarine and spreadable fat products**

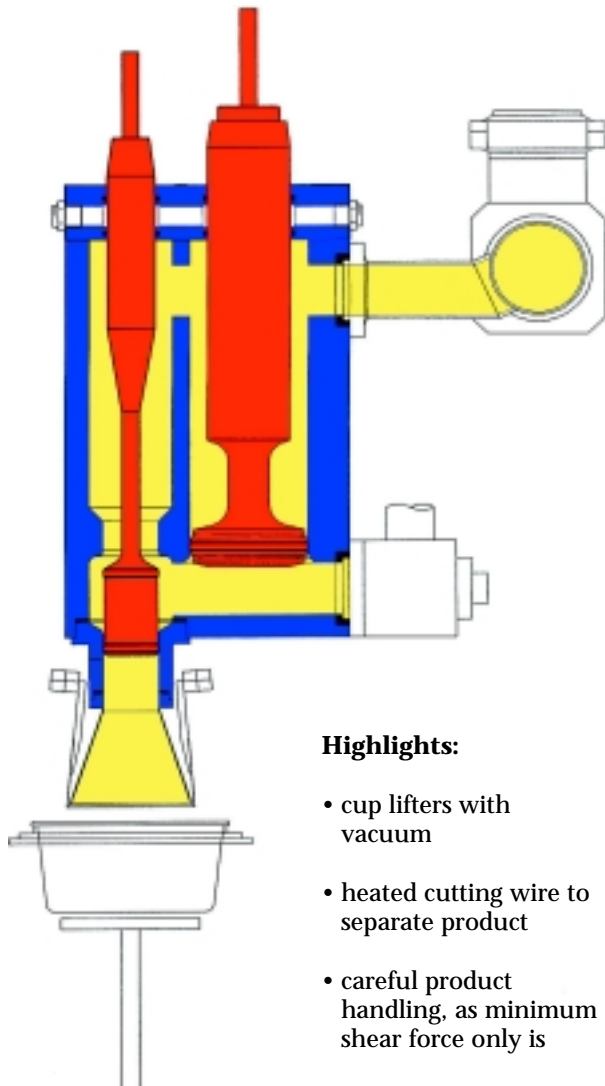

Highlights:

- cup lifters with vacuum
- heated cutting wire to separate product
- careful product handling, as minimum shear force only is

exerted to product and only a minimum amount of product is handled by the compensator

- no crystallizing of the product in the filler, as it is directed to the re-work line if the machine stops and the product becomes continuously exchanged within the filler

- filling pistons individually adjustable

- highest possible filling accuracy

- no mechanical wear

- continuous product flow

- CIP cleanable

- sterilization by hot water

- patented design

Closing principles:

- snap-on-lid closure
- advertising leaf with snap-on-lid closure
- heat-sealing closure with snap-on-lid closure
- foil from roll stock with snap-on-lid closure



ЦАМВА

HAMBA Filtec GmbH & Co. KG
Im Langental 6
D-66539 Neunkirchen
Tel.: +49 (68 21) 40 13-0
Fax: +49 (68 21) 40 13 149
www.hamba.de